



SPECIFICATION SHEET

PVE 40 PR

Powerful, Versatile and Efficient Piling Rig

High capacity
Very reliable

Very quick to assemble
CAT engine

Fast and efficient
New type of cabin



PVE 40 PR

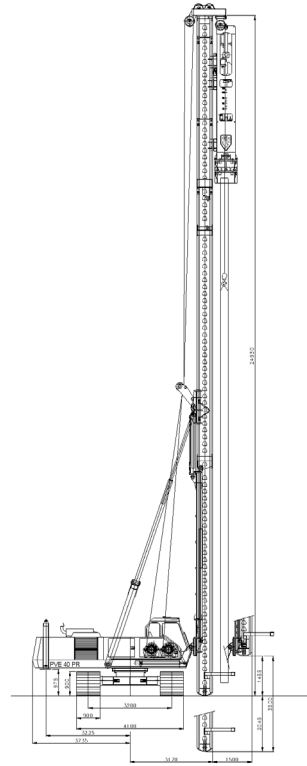
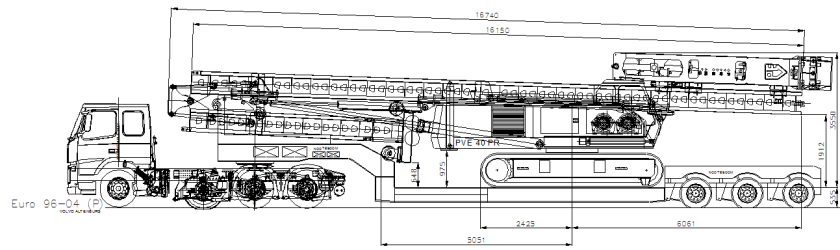
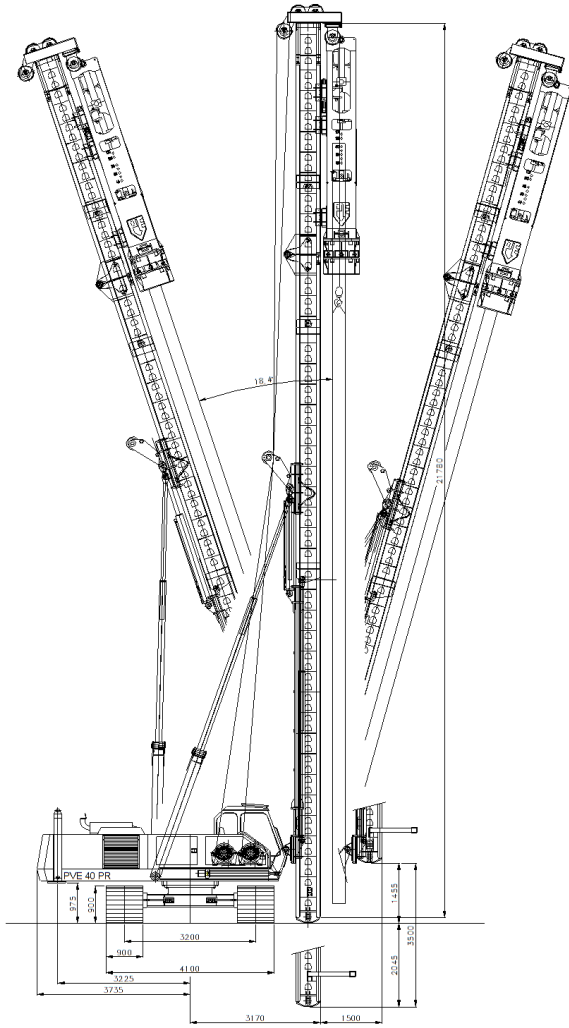

all dimensions are in millimeters

Technical specifications

Max pile & hammer weight	28,660 lbs	(14.3 US Ton)
Hammer winch capacity	17,636 lbs	(8.8 US Ton) / Free Fall
Pile winch capacity	13,228 lbs	(6.6 US Ton)
Optional aux winch capacity	6,613 lbs	(3.3 US Ton)
Standard leader length	71.5 ft	
Maximum leader length	81.3 ft	(55 ft. Pile)
Diesel engine	Caterpillar C-7.1 Teir 4 Final	
Rated engine power	250 HP	1800 RPM
Hydraulic system	Open Loop	
Hydraulic pumps	Bosch-Rexroth	(Dedicated pumps for hammer and valve bank)
Hydraulic valve blocks	Bosch-Rexroth	
Transport width	10.83 ft	(Hyd. Retracting Tracks)
Transport length	54.92 ft	(Hyd. Folding Leader)
Transport height	11.65 ft	(Includes Hammer)
Recommended hammer	PVE 4 NL	(35,400 ft.lbs)
Weight base machine (excl. hammer)	88,185 lbs	(44.1 US Ton)

